

From the „logic of the molecular syntax“ to molecular pragmatism
Explanatory deficits in Manfred Eigen's concept of language and communication

Abstract

Manfred Eigen employs the terms language and communication to explain key recombination processes of DNA as well as to explain the self-organization of human language and communication: Life processes as well as language and communication processes are governed by the logic of a molecular syntax, which is the exact depiction of a principally formalizable reality. The author of the present contribution demonstrates that this view of Manfred Eigen's cannot be sufficiently substantiated and that it must be supplemented by an approach based on linguistic pragmatics.

Keywords

Syntax, semantics, pragmatism as structural and organizational principles in living nature as used by Manfred Eigen and in a molecular pragmatism.

Introduction

„Genetic code“, „nucleic acid language“, recognition sequences“, „translation process“, amino acid language“, „immune responses“, „intercellular communication“, etc. owe their status as irreplaceable core concepts in molecular biology not to an introduction into biochemistry and molecular biology by linguists, communication experts, or language philosophers. Rather, they were independently coined by molecular biologists to explain observed phenomena and were clearly invoked due to the strong analogy to processes of human communication.

Here, I attempt to show that the use of these key concepts in biochemistry and molecular biology - when viewed under the premises envisioned by these fields - is problematic. To exemplify this problem I refer to the terms „language“ and „communication“ as used by Manfred Eigen. His research has had a substantial and lasting influence on biochemistry and molecular biology as well as on evolutionary theory. Numerous researchers in these disciplines use the language and communication concepts in the same or similar context as Manfred Eigen.

The present paper is part of a broader, interdisciplinary argumentative strategy seeking to demonstrate that living nature is structured and organized in a linguistic and communicative manner. The methodological basis for this approach lies in a modern philosophy of language pragmatism and its links with modern semiotics.

1. Manfred Eigen's use of the terms „language“ and „communication“

1.1. Molecular recognition processes and their significance for genetic manipulation

In the book he coauthored with Ruthild Winkler, „Das Spiel. Naturgesetze steuern den Zufall“

(EIGEN/WINKLER. 1987), Eigen refers to a language concept which clearly leans on that of information theory, particularly John v. Neumann's idea regarding a self-reproducing, intelligent automaton. For Eigen it is beyond doubt that life in the biological sense originated according to the laws of physics and chemistry; it need only be investigated with sufficient rigor under these aspects for its function and therefore its genesis to be exactly defined. *The goal of this research approach is to provide techniques with which organisms can be created artificially.* In Eigen's mind, this artificial creation of life does not involve an entirely „de novo“ creation, but rather a distinct improvement of genetic manipulation techniques.

The information concept is central to Eigen's position: it best describes and explains the storage of all the structural features of an organism in the chromosomes. According to Eigen, genetic information is laid down in the form of a molecular text which, in the case of humans, has the scope of a well-stocked private library (207). In the context of genetic manipulation, this very aspect of a genetic text encompassing the entire genetic information of an organism prompts Eigen to raise the problem of how to „track down and exchange“ (ibid.) the detailed information that codes the substructures of an organism.

The identification of such substructures poses no problem for Eigen, since „the relative arrangement of the individual genes, the gene map, as well as the syntax and semantics of this molecular language are (...) largely known today“ (ibid.). The problem to be resolved is one of „engineering“ (208), i.e., the techniques required to modify the genetic text. Eigen compares this with the problems in organ transplantations, only that molecular dimensions are involved and therefore the corresponding „micro-tools“ (ibid.) are required. On the other hand, „gene transplantations“ need not be specially developed, but merely discovered, since the entire instrumentarium has already been produced by nature. This range of tools need only to be isolated from living organisms in order to be applied. The naturally produced instrumentarium to manipulate the genetic text consists of restriction enzymes, which cut the genetic text at specific sites. „The site consists of a palindrome-like sequence of six letters of the genetic text“ (208f.). Eigen specifically lays down his conception of this identification process: „The restriction enzyme recognizes a palindrome-like symmetry of the genetic text“ (210).

This capacity to identify specific text sequences must be strategically applied by researchers who wish to carry out genetic manipulations. The restriction enzymes should be able to carry out their identification and text cutting techniques at any site.

„Since the genetic molecular language makes use of four different 'letters', one can envision a multitude of cohesive recognition characters, depending on the length of the symmetrical recognition zone“ (209). The exact nature of the recognition process by the restriction enzymes is not yet known. We do know, however, that the enzymes recognize the palindrome-like sequences as cutting sites and that this is the general rule „by which genetic texts are marked for the specific recognition by the executive function of the proteins“ (209).

1.2. Self-organization and the logic of „self-reproducing automatons“

For Eigen, the principle of self-organization lies behind the organization of biological structures. He uses the human brain and its function to exemplify this principle. The brain consists of nearly 10 billion nerve cells, each of which develops approximately 10 000 to 100 000 specific contact sites with adjoining cells. The goal is to find the basic rule governing this

complexity - that principle of hierarchic organization which enables cells to differentiate such a complex network.

Among the many explanatory models, Eigen sides with that of A. Turing: Turing postulated a universal computing device (similar to the human brain) which, upon exact instruction, „calculates the value of supplied functions“ (215) and is capable of independently discovering general mathematical procedures, so-called algorithms. The computing device would store these and use them as a basis for new operations, enabling it in principle to derive any calculatable function in a series of finite calculating steps. The device therefore stores all the initially entered computational rules along with all the newly derived ones and uses both in every algorithmic operation. The most significant advance of A. Turing's approach, in Eigen's opinion, involves John v. Neumann's concept of a „self-reproducing automaton“. Eigen describes Neumann's idea, which represents a „mathematically exact“ refinement of Turing's idea, in the following manner: „Every machine consumes free energy - it either uses electrical current or is powered by an internal combustion engine; in short, it could not function without this metabolism. A specific operational task of the v. Neumann automaton is self-reproduction. The first model from the year 1950 was entirely realistic in its conception: The machine runs back and forth in a huge spare-parts warehouse and compiles the components necessary for its own replication. Most importantly, it also reproduces its own construction plan or blueprint. Its progeny should, after all, also be equipped with the self-reproduction capability. Herein lies the possibility to perfect the v. Neumann automaton, an idea that has long been taken up by theorists: selective alteration of the program enables continuous improvement and an expanded range of application in the sense of Darwinian evolution“ (216f.).

Eigen refers the *theoretical construction* of the self-reproducing automaton *to a reality in which these automatons comply with Darwin's theory of biological evolution*. According to Eigen, v. Neumann achieves this by referring to the individual components of the automaton as cells and then assigning each cell a certain number of states which largely consist of relationships to neighboring cells. This simulation of the nerve cell network in the human brain would give rise to an optimal number of interconnections; these, in turn, would enable the quantity of calculations that the Turing machine requires to solve its problems. „In principle, the automaton is capable of carrying out any desired calculation“ (217). The cellular organization of the brain follows exactly this principle and is thus comparable to a cell automaton. Brain function, and thus speaking (thinking), are brain computations analagous to those of the self-reproducing automaton.

According to Eigen, an artificially constructed organism would require features resembling those of the above automaton. With this concept, Eigen has, in fact, set his sights on explaining the origin of life, or of organisms, through self-organization. This would require:

- a) a memory large enough to develop the algorithms;
- b) a number of adaptive capabilities permitting continuous changes in and expansion
- c) an intrinsic evaluation scheme within the machine.

Such an evaluation scheme is a prerequisite for the machine to be able to select the correct development from an array of theoretically possible variants. „Nature, through the development of receptors that register environmental signals and through the development of nervous systems that can process and store such signals, has found a more economic way“ (225) than a machine whose construction is guided by the principle that improved construction plans benefit not the

present, but only future generations.

Nature's more economic approach enables learning processes that impart significance even to important changes *within one and the same organism*. The learning process of such biological systems demonstrates how the reproduction, evaluation, and modification of the elementary processes in the learning system function as *selective processes*. Eigen does recognize the importance of „evaluation“ for his automaton model of life.

„The Turing automaton must therefore have an inherent, independently active evaluation scheme that ‘motivates’ it to do certain things and refrain from doing others. It requires a pleasure and a pain center; it would have to experience fear and delight. This, at least, is how an ‘animate’ being learns“ (ibid.).

Eigen views the evaluation function as a mental phenomenon. It thus ranks as a fundamental, computable function; one need only to definitively pinpoint the corresponding centers in the human brain to differentiate and reproduce the principles behind the operating mechanisms and, in Eigen's sense, to integrate them into a self-reproducing automaton. From the cognitive standpoint at least, no difference from humans would remain.

1.3. Levels of self-reproduction: Eigen's implicit epistemology

The incredible variety that characterizes nature could not have been the result of a uniform principle of self-organization. Rather, various levels of self-organization must be assumed. In Eigen's opinion, Popper's 3-World-Concept, which J. Eccles applied to the organization of brain performance, is best suited for such a differentiation.

Accordingly, the world is divided into World 1 - the objects - to which our questions pertain. This encompasses the energy of the cosmos, the structure and actions of all organisms and all human brains, but also includes the objects artificially created by humans along with material substrates of human creativity (works of art), tools, machines, books, etc.

World 2 contains purely subjective knowledge, the experience of perception, thought, emotions, remembrances, dreams, creative imagination, i.e., the imaginative faculty. This world of the subjective is distinct from the world of objects and from World 3.

World 3 harbors knowledge in the objective sense - the cultural heritage recorded on physical media and covering the fields of philosophy, theology, natural science, history, literature, art and technology, yet also including the theoretical systems of scientific problems and critical arguments.

Thus, Eigen envisions a world whose materiality can be found in World 1 (including the materiality of the human beings that devised this system). His perceptive experience of this concept and the existence of the thinker as subjective „self-awareness“ corresponds to World 2. Finally, World 3 encompasses that which the thinker thinks, as an intellectual substrate (insofar as it has been recorded in a book or other medium).

Eigen considers this interpretation model of the world to accurately reflect reality - a reality from

which the rules governing the self-organization at the various levels (Worlds 1,2,3) should be able to be extracted.

„Organisms are formed from disordered, unorganized matter. This requires the development of a molecular language with which information can be ordered and transferred. This, in turn, presupposes a genetic memory enabling a program as complex as that of the human bauplan to develop in a *stepwise* manner“ (287).

These comprise processes of World 1. The quality of human thought and feeling would derive from the function of neuronal stimulatory patterns of the brain, which are the material expression of subjective feelings.

„The learning process in the central nervous system of (higher) animals takes place in an analogous manner. A communication medium, an ‘inner language’ for transferring and processing the environmental impressions received by the sensory organs, is necessary here as well. These are encoded in the form of electrical stimulation patterns in the network of nerve cells. The electroencephalogram is an externally inferable (weak) echo of the uninterrupted, highly diverse communication between nerve cells“ (ibid.)

The brain, after all, is the very instance that carries out the evaluatory process that decides on the efficiency of the information-processing system: it filters the „correct“ information from a wealth of potentially important information.

„The memory localized in the network of switch contacts or synapses is responsible for a selective evaluation of incoming information. The resulting continuous modification of the memory structure, the engram, determines the makeup of the subjective experience comprising World 2“ (287f.).

In Eigen’s opinion, subjective experience, or the totality of the relationship between subject and world, is based on the continuous change of existing rules by newly developed ones; this parallels the automaton model of calculating devices that function algorithmically. (*Here, Eigen provides an implicit transcendental foundation of the constitution of subjective experience*).

Finally, World 3 is reserved for the products of the human intellect, including the development of a language which can be employed to proceed independently in the automaton-theoretical sense.

„Among all organisms, man alone has developed a language built on logical principles; it serves to transmit, exchange, and recombine the rather limited subjective experience and thoughts conveyed by the sensory organs“ (288).

This considerably expands the horizon of traditional evolutive processes: human language liberates mankind from Darwinian constraints and enables him to partake of the cumulative experience amassed during cultural development. In lower evolutionary levels, on the other hand, new combinations always only benefit the following generation, never those who gave rise to the new combination. This world of information storage in books and other documents of the human intellect, this is World 3.

The central element in the competition between self-reproducing structures is the intrinsic evaluation scheme. The essentiality of this principle is not based on the principles of self-organization alone; it is also coupled with the „conditions forced upon us“ (289) by the real, living environment.

„The evaluation scheme of mental information, together with stimulus processing controlled by a nerve center, is a product of evolution. It was initially based solely on the selection of advantageous, genetically pre-programmed behavioral patterns. The development of evaluation centers in which pain, fear, and pleasure are localized expands the latitude for the directed response to environmental stimuli of all kinds. (...). Only in humankind does the evaluation scheme of mental information attain individual independence“ (ibid.).

The self-organization levels of the 3 worlds also correspond to the evolutionary levels. It is interesting to note that cognitive processes are the result of subjective brain processes, while the relationship between subject and external world can be interpreted as an input-output system from the standpoint of information theory. This is the opinion of Eigen.

1.4. Structures of language

Eigen's explanatory model for the self-organization of intercommunicating organisms leans distinctly on the mathematical theory of communication - the information theory. He repeatedly presents both molecular and human language as a reflection of *one* reality and deduces the function of language from the material conditions of information-processing systems.

"The existence of `language` is equally important for the material self-organization of organisms, for human communication, and for the evolution of ideas. A prerequisite for the development of a language is an unambiguous symbol assignment. In the molecular language it involves defined physico-chemical interactions; in communication between humans it is based on phoneme allocation and its graphic fixation. The allocation of meaning to the symbol combinations as well as their mutual relationships stem from an evolutionary process based on functional evaluation. According to Chomsky, the inherent structure of all languages exhibits common features which reflect a functional logic based on the mode of operation of the central nervous system; this parallels the molecular mechanisms which gave rise to the genetic language" (291).

Language thus becomes the product of language-producing organs. These organs are structured according to the principles of self-organization and form a functional logic of the network hierarchy of brain cells. Their logic, in turn, structures the language. The allocation of meaning to the symbol combinations, i.e., the sense of a sentence, arises from evaluation criteria of a functional nature, that is, it develops from an agreement reached in the course of intersubjective information exchange; depending on the symbol arrangement, this agreement could have taken on a completely different form.

Language is a symbol arrangement formed according to physiological criteria, to which meaning is then attributed. It **clearly** mirrors - and this is one of the key points in Eigen's conception of language - *reality in its syntax, which obtains its structure from the organization of the nerve cell network*. Eigen's language model aims at a quantification and formalization, while the evaluation and allocation of meaning to expressions and contemporary usage represent

marginal conditions or are merely supplementary, not essential constituents of language.

1.5. The information concept: the constitution of meaning through syntactic structures as the logic of material reality

For Eigen, the information concept is closely allied with the concept of form or gestalt. Information is, so to speak, an abstraction of gestalt or its representation using the symbols of a language. „Just as the essence of a gestalt combines concreteness *and* functionality, information also has two complementary aspects: a quantitative, numerical one and a qualitative one examining the meaning and significance of the symbol arrangement“. (292)

Eigen shows special interest in the information concept, particularly as it pertains to the quantitative aspect, i.e., what is the minimum amount of information required to enable exact identification of the symbol arrangement. This measure of information is equivalent to the amount of „yes-no-decisions“ necessary to identify all the symbols of a sequence“ (ibid.). In principle, every wholly unknown text can thus be deciphered by quantifying its symbol arrangement. The text itself is irrelevant, e.g., in the event that speakers formulated it with different intentions or as an expression of various intents. Only the actual symbol sequence is of import.

Nevertheless, Eigen recognizes a differentiation between an „absolute, quantifiable“ and a „sense-providing, semantic information aspect“ (294). The latter is responsible for the complexity of language. This complexity, however, is itself the result of the complexity of the brain (Eigen, in accordance with Bar-Hillel): *the semantic aspect is thus the result of the syntax of the network hierarchy of brain cells.*

Therefore, according to Eigen, the „scheme of language communication“ can be characterized by a flow diagram in which A represents a source of information of practically unlimited productivity.

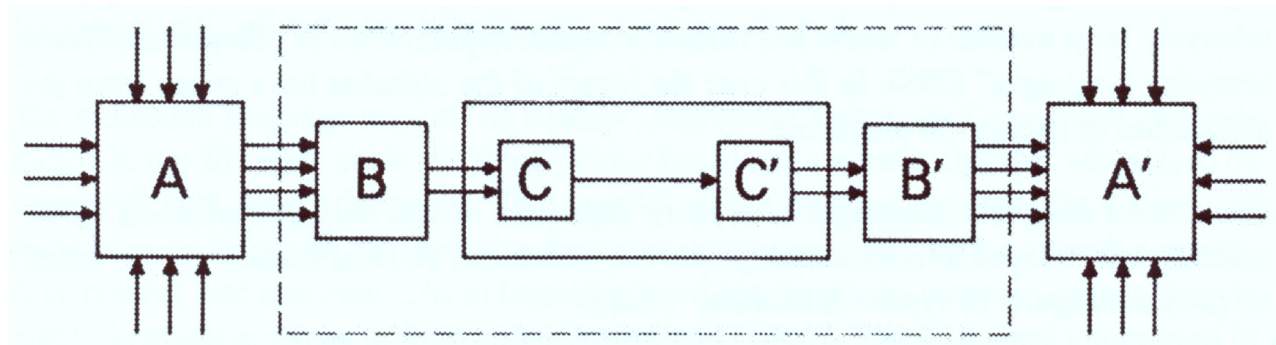

Fig. 1: „Communication diagram“ (from: EIGEN/WINKLER. Fig. 56; 1975, p. 294)

This message is compiled in B. There, the „incoming environmental information“ (294) from the sensory organs - after „evaluation“ based on „programmed“ mechanisms - is combined with the experience stored in memory. Finally, the information from A, which is produced in B, is sent through C in the form of physical signals.

This user of a linguistic sign is mirrored by a receiver, who receives and evaluates this information in an analogous manner in the reversed sequence C', B', and A'. The key step in this communication model, the one involving the transfer of information, is that between C and C'. Actually, it only involves technical processes such as the coding of information to enable mechanical processing. The information theory is primarily concerned with this aspect along with the structural implications in the domain B and B'. The information theory clearly distances itself from the problems surrounding A and A' and relegates this topic to psychologists and philosophers. For Eigen, aspects such as sensory experience (= observation) and communicative experience (= comprehension) are processes which take place in the centers B' and A' as opposed to in A itself.

The question regarding the discovery of those laws governing the central nervous system of humans is, for Eigen, one of physics according to the rules of nature. Eigen remains convinced that the function of the central nervous system can, in principle, be quantified by sufficiently thorough research. It is erroneous to conclude that full quantification of brain capability is not possible since humans would simultaneously be the subject and object of such research, and that this would involve an apriori of understanding principally hindering quantification (296).

Specific powers of consciousness are, rather, interrelationships between the complementary halves of the brain, which are joined together through 200 million nerve fibers and which can transmit 4 Million Million electrical impulses per second. This quantity no doubt suffices to explain all functions.

1.6. The allocation of symbols and meaning in the human language

The fixation of spoken language in symbols and letters also involves specific allocations. „Symbol arrangement in speech is clearly defined in every case. The reason behind the relatively large number of letters lies in the functional requirements of phonetically based everyday languages“ (298). In this case the letters of the alphabet have arisen from the abstraction of approx. 50 phonemes.

In standard computer languages it is more expedient to use only two symbols. „The mechanically relayed interrelationship between transmitter (C) and receiver (C') is based on the unambiguity of symbol allocation“ (ibid.).

If the allocation of symbols to individual sounds in speech is clear, then Eigen considers the allocation of meaning to the various symbol sequences to be equally unambiguous. This process, however, is far from complete, as evidenced in the language of poetry, where new meaning is conferred through plays on phonemes. The combination of words into sentences is an allocation problem as well, with a sheer incalculable number of sentence combinations.

Eigen draws on Noam Chomsky's language interpretation, in which „sentence structures, if we disregard the specific peculiarities of the individual languages, exhibit parallels that indicate a universal regularity evidently originating in the organization of the human brain“ (301). Eigen (along with Chomsky) refers here to the structures of a universal syntax, a general syntax configuration „as may have underlain the acquisition of speech in evolution“ (ibid.). The intrinsic

rules of Chomsky's generative grammar - the production and transformation rules - are of particular interest to Eigen. The fact that a consequent formalization of speech reveals discrepancies vis-à-vis colloquial usage is only a marginal problem for Eigen. The reality of the informal language that we normally deal with, however, is characterized by its open-endedness, whereas Eigen's formalization postulate presupposes a closed language system.

Eigen defines the relationship between language and reality such that *language reflects a formalizable reality*. The reality of objects is subject to the same laws as the materiality of our bodies and the self-organization of our brains. This brain is necessary to enable and determine both consciousness and language. Overall reality reflects a universal syntax which, in certain organisms, appears in the form of speech.

1.7. Molecular semantics

Eigen illustrates the relationship between the language symbols and the designated object (the semantic level of language) by comparing human language with the molecular language of biological organisms. He takes a cue from a quote by C. F. v. Weizsäcker („The relationship between chromosome and the developing individual appears to be such that the chromosome speaks and the individual listens“; 304). The conclusion: in the individual, the „communication channel“ from chromosome to organism is one-sided and can be more accurately described as an issuing of commands. Intermolecular communication - the „discourse“ (ibid.) between molecules - is restricted to the phenotypic level in the form of an „‘object language’ oriented toward functional optimum criteria“ (ibid.).

On this level, Eigen detects analogies between this „phenotypic, molecular functional language“ and „phonetically based spoken languages“ (ibid.).

The molecular language requires an equally „expressive alphabet“. Eigen refers here primarily to the 20 amino acids and their various functions, a protein alphabet which is to be compared with human language. The „words“ of the protein language, the amino acid sequences, represent all the executive functions within organisms such as reaction mediation, control, and transport. „As in linguistic word combinations, several - approx. four to eight - symbols combine to form a cooperative unit“ (ibid.). Eigen attaches importance to the circumstance that these functionally operating symbols in protein languages are not merely rowed linearly but are „arranged according to their respective chemical task in a specific spatial coordination“ (ibid.). Specific chain elements between the amino acids are responsible for this spatial coordination. Enzymes themselves are word elements of the amino acid language.

„Although the active center - the actual three-dimensional word correlate of the protein language - comprises no more characters than the number of verbs in spoken language, the protein molecule must unite a total of between one to five hundred chain elements within itself in order to form such an active center. Each one of these molecules represents a particular task and one could describe the enzymes as the ‘verbs’ of the molecular language“ (305).

The detailed and functional coordination of all organizational and production processes within an organism is, according to Eigen, the result of the functionality of this language. Heredity marks the limits of this functionality.

„All words of the molecular language are combined to a meaningful text, which can be broken down into sentences. The transmission of this text from generation to generation and the information flow between the legislative and the executive branch within the cell cannot be accomplished with the protein alphabet, which is geared toward functional efficiency“ (305). Eigen equates the legislative branch with the nucleic acid language; it is structured according to economical considerations, much as the alphabet of a computer „or some other type of mechanical information transmission“. This alphabet uses a codeword consisting of three nucleic acids for each letter of the amino acid. The allocation from codeword to letter is unambiguous; this is not true in the other direction: numerous amino acids have more than one codeword. Rather than using 2 characters as in the case of computers or telex codes, this language uses 4 characters because its construction was based not on logical criteria but on a natural process linked with the protein alphabet (ibid.). The manifold structures of biological species, their diversity and differentiation, could only have evolved through sequence combinations involving four letters; a simple pair of letters would have been insufficient. This nevertheless weakened the „teleonomic‘ demand for a high level of economy in the transfer of genetic information and for a universal concept of the encoding enzymatic machinery“ (305).

1.8. „The vector character of the communication flow from chromosome to organism“

In discussing the direction of this dialogue, Eigen refers to Arthur Kornberg and his tenet „DNA-RNA-PROTEIN-everything else“ (306). According to the above 3-World-Concept and Eigen’s 3-World-Language Model, the Kornberg equivalent can be stated as follows: DNA is the storage site, the memory for genetic information. RNA transmits this information, and the protein is the executive form of the information. „Everything else“, the life process itself, is a subsequent development.

„Speech, communication, reading, and comprehension on this level merely means binding (= recognizing) the complementary molecular building blocks (=language symbols) and linking them into a macromolecular ribbon (= text)“ (307).

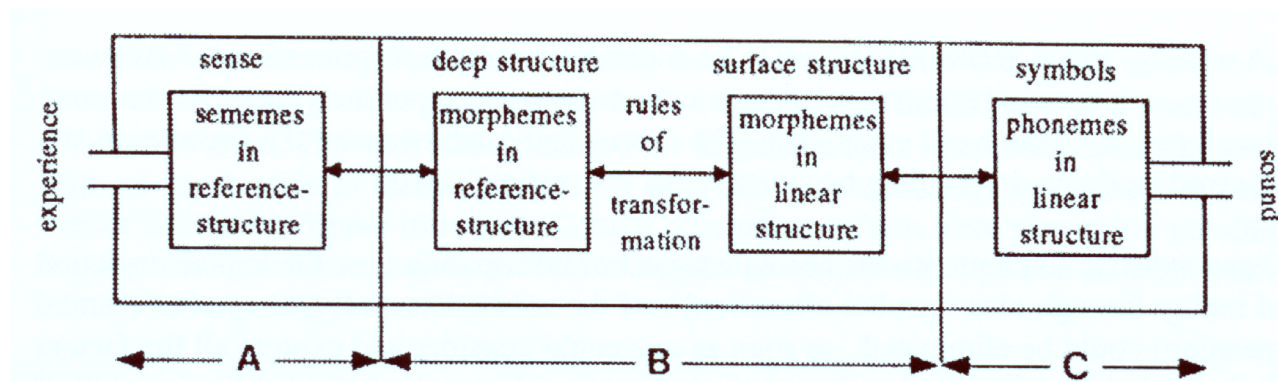

„In the above diagram, William G. Moulton characterizes the communication system of human language.“

Fig. 2 Figure text from: EIGEN/WINKLER. 1975, p. 300

As a rule, the information transfer in the outlined language model of Moulton flows from A to C

and in the present case also from the DNA to RNA: At the same time, reversals of this direction have been recorded, for example in retroviral infections where RNA sequences develop first and are subsequently copied into DNA sequences. Since DNA is the more stable form, it has been speculated that RNA sequences are evolutionarily older.

Accordingly, they would have contributed substantially, as a language, to the genesis of the nucleic acid language; DNA would thus represent the more stable, reliable form of fixing RNA creations and using them in reproduction (specifically, in hereditary transmission). In Eigen's words, „initially, in the phase of de-novo synthesis, a great many phantasy products apparently develop. Under selection pressure, however, only the best adapted sequence becomes chosen (...). The best adapted sequence is that which can be reproduced the quickest and most accurately and also has the greatest stability“ (308).

In Eigen's opinion, „a clear divergence of roles between geno- and phenotype“ took place, especially in the differentiation of the translation mechanism from DNA to RNA. Eigen answers the question regarding the subject of the translation - the subject of the language sign usage in the production of those phantasy products in the de-novo synthesis - both holistically and materialistically: Molecular semantics provides language signs with meaning according to physical laws.

„The representation of phenotypic reality in the genetic language (in an analogy to the memory capacity of the mind we can refer to it as 'genetic reflection') is a consequence of evolution in toto. We are dealing with the generation of information. This applies to information in our brain as well: it can only arise in an evolutive manner, i.e., on the basis of selection. In this case, however, the underlying elementary processes we are dealing with involve time scales of milliseconds“ (310).

1.9. „Understanding“ as a reversal of information generation

Eigen then poses the question of whether information reveals itself to us as something already in existence or whether it is an actual creation. In his opinion, information is both creation and revelation. These features provide the process with its evolutive quality.

„A message that is received is meant to be understood. It must therefore 'reveal' its meaning, i.e., relate to existing experience or conventions and reproduce these. At the same time it can also enrich our experience. The subsequent establishment of a connection, the integration, the understanding becomes an act of creation“ (310).

Eigen's distinction between the absolute aspect of information (i.e., the logical depiction of reality through clear symbol allocation) and the semantic aspect (the symbol's actual meaning) could be eliminated „as soon as one could consider and express all the factors in the probability distribution that are important for its meaning“ (ibid.). The reversal of the information generation process would guarantee an adequate and comprehensive understanding of information: all of the individual factors contributing to its development, and their interrelationships, could be reconstructed. Understanding in this sense would mean systematically narrowing down the probability distribution of semantic alternatives until only a single alternative remains. This would represent both the absolute and the semantic aspect of the respective information.

This type of information gain - information as a message clearly understood to convey

information - has been quantitatively defined by Shannon and Rényi, who, in Eigen's words, „started out by considering the probability distribution before and after the arrival of an additional piece of information and calculated the median information gain by comparing the modified individual probabilities“ (ibid.).

Understanding an information-containing expression would involve a process in which all the possible alternative meanings of that information, *with one exception*, could be „attributed a probability of realization equal to zero“. Narrowing a probability distribution down in this manner can be achieved physically only through irreversible processes.

„A sudden event causes an initially conceivable condition, characterized by a certain probability, to become unstable; it collapses. A new situation, leading to the exclusion of previously conceivable alternatives, arises“ (311).

Eigen's communications model has its basis in formalizing criteria and would not be possible without the maxims of the picture theory of language. Even the reflection on thought (described in philosophy as transcendental reflection) is considered to be a process of self-organization that is principally quantifiable and, through the construction of learning machines, qualitatively modifiable as well.

Nature develops a brain based on mathematical and physical (obeying an inner logic) natural laws; this brain derives the lawfulness within itself from a universal syntax and functions according to this syntax. Phoneme allocation enables a correct depiction of reality in a formalized scientific language. *The brain mirrors its own principles of organization in this language*. This is merely the endpoint of a biological evolution which began on the lowest molecular level and thus, from the evolutionary point of view, was initially defined by the nucleic acid language.

„A selectively advantageous mutant arising from a reading error (i.e., from a statistical fluctuation) in the genetic program can lead to the irrevocable collapse of a previously stable population. The 'new' information owes its genesis to an irreversible event; it stems from an „evaluation of meaning“ (this is, after all, what selection represents). One can concur with Karl Popper in saying: Certain alternatives which were previously possible become falsified. An analogous process must take place in the brain when an observation is made or a message is read“ (311).

At this point, Eigen draws an analogy between molecular information and human communication: both have a common process of information generation in which symbol allocation is subject to a selection, i.e., evaluation, process where possible meanings are irreversibly eliminated until only a single one remains. In his view, the understanding of meaning on both the molecular and human level involves a reduction to zero of all possibilities of realization, with the exception of one alternative. Molecular semantics and the semantics of human languages (at least in the case of formalized scientific language) are based on a selection process, a falsification process.

For Eigen, Popper's falsification criterium in science theory, originally designed to decide on the quality of quantifiable theories, is itself not amenable to theoretical discussion and does not represent a falsifiable evaluation model; rather, it is an expression of a reality in information-

perception in which the brain lends expression to its own form of organization along with the underlying logic.

1.10. Molecular genetics and generative grammar

Eigen also draws attention to the discrepancies arising from the „juxtaposition of molecular and phonetic language“ and which reflect „the different nature of function“. This no doubt indicates that Eigen does not entirely dismiss the pragmatic aspect of the language sign usage, although he attributes only marginal importance to the user of linguistic signs. „Each language primarily reflects the characteristic features of the respective, underlying communication machinery“ (313f.).

The term „communications machinery“ is used by most of the top researchers in the fields of biochemistry and molecular biology; it can also be encountered in connection with terms such as „protein synthesis machinery“ (DARNELL. 1985) or in slightly modified form as „evolutionary mechanism“, „communication mechanism between molecules“ (PRIGOGINE. 1980, 1984), and „enzyme machinery“ (DELBÜCK. 1987). This demonstrates a broad consensus that v. Neumann's automaton theory, or the mathematical theory of communication, can serve as an undisputed basis for the explanation of all living phenomena.

Let us return to the differences between the molecular and phonetic language. The respective language structures differ much in the same way that the different functions in the molecular and phonetic fields lead to a different „communication machinery“.

„The expression form of genetics are sentences whose structure is determined by control functions. Thus, in the operon segment of the bacterial genome, numerous functionally interrelated structural genes are united by control units, so-called operators. The entire genetic description of the bacterium, the genome, consists of such sentences, which are interconnected within a single giant molecule. The chromosomes of more highly developed organisms have a highly regionated structure which is clearly visible even under the electron microscope; the details of its 'syntax', however, remain largely unknown“ (314).

Here, Eigen clearly expresses what biochemists and molecular biologists interpret their observations to be. He describes the biological structures that code the organism's structure and developmental plan as a genetic message „fixed in sentences“. The form of the genetic information corresponds with control functions.

The sentence construction of phonetic languages also exhibits general structural principles. As determined by Chomsky, the inherent structure of phonetically articulated sentences reflects structures of a universal grammar „which are intimately related to the 'generative' organ of language, the brain“ (314). New sentence combinations, formed to promote understanding in the discourse between members of a social environment, are the result of generative, syntactic operations of the brain. When human beings reflect on their cognitive abilities, the brain forms syntactic sentence structures using these underlying, universal syntactic rules. *Accordingly, self-knowledge in humankind is a depiction of brain functions through generative syntactic operations of the brain.*

The analogy between molecular genetics and phonetic languages, coupled with the

universal generative grammar common to both (as a manifestation of the logic inherent in the material) leads Eigen to the conclusion that:

„At any rate one can say that the prerequisite for both great evolutionary processes of nature - the origin of all forms of life and the evolution of the mind - was the existence of a language. The molecular communication system of the cell is based on the reproductive and instructive features of nucleic acids as well as on the catalytic efficiency of proteins“ (314f.).

At the same time, the similarities and dissimilarities of molecular genetic and phonetic languages go beyond this. Memory capability, in particular, clearly demonstrates these differences in forms of communication and language usage: While antibody formation in the immune system takes place independently in each individual, memory involves regulated interactions between antibody molecules and learned features. Memory takes place on the molecular level.

"Each individual immune system therefore has its own language. The 'vocabulary' is determined by the spectrum of antibody-producing cells. The correct usage of this language emerges from a learning process and is subject to constant modification“ (328).

The organization of the immune memory is a regulated interaction process between all protein individuals (enzymes) involved in the immune response. Even minute deviations from these rules endanger the efficiency of the immune response and consequently the survival of the entire organism. It is the network of these interactions which enables an immune response flexible enough to adapt to new requirements, to modify itself, and to build upon and expand the stored memory of previous immune responses. The immune response can thus always incorporate the stored experience and improve its efficiency.

Brain cells, as the epitome of the evolution of the central nervous system, form a similar structural network to organize memory capability. As opposed to the indirect interaction of protein individuals in the immune system, the cells of the central nervous system are directly interconnected - via synapses as switch contacts - and interact by means of electric impulses and chemical substances. The interaction is more complex and is considerably more rapid.

„Naturally, electric communication over greater distances can be effected at much greater speeds than chemical communication involving material transport. Learning processes which require hours or days in the immune network take place in fractions of a second in the brain. At the same time, the fixation of that which is 'experienced' or 'learned' is again a material process“ (329).

The junction between the nerve cells, the synapses, are extremely adaptable. „They develop, vanish, and constantly change their contact features as a result of the communication“ (329).

In the central nervous system, memory and recollection, learning capacity, and imagination are fixed as specific stimulatory patterns and can therefore be rapidly recalled as information or informational context; the process of reading and transcribing genetic information involves entirely different mechanisms. Only the stable storage takes somewhat more time because complex information can only be recalled through a specific circuitry and this requires organizing a functional network of synapses and specific (informationally adequate) network structure.

„Neurons have the highest metabolism of all cells in the body; that is, they continuously produce

ribonucleic acids and proteins, yet not to store the information *within* these molecules, but to employ them in developing a modifiable, *functional* network“ (331).

For Eigen, this description and interpretation of observed phenomena through the information theoretical model is self-referential. It is obvious to him that these conditions for potential self-organization in the various networks - both molecular, molecular-cellular, and intercellular types along with all their functions in the realm of genetics, in the immune system and in the central nervous system - are the same as the conditions of their scientific description.

Eigen can make no distinction between the language of the observation of events and the language of the theory about the interpretation of these observations. The preconditions for self-organization „mirror themselves in the uniform structure of the theoretical approaches used in their description“ (331).

2. Philosophical implications of Manfred Eigen’s language and communication concept

The comparison between the molecular and human language, as undertaken by Eigen, is problematic because Eigen believes he is able to fully explain human language and language in general by means of an implicit depictive theory. In his interpretation of language and communication, the pragmatic aspect, i.e., the relationship between language signs and the user of these signs, is reduced to a marginal condition in the theory of language, while the semantic aspect is reduced to rules of a universal syntax.

When viewed in this light, Eigen’s usage of the terms language and communication takes on a *purely metaphorical character* that can only be avoided if these terms are understood and used in their broader sense. Summarizing Eigen’s language concept reveals the following features:

2.1. Language as a quantifiable set of signs

The world behaves according to physically determinable natural laws. These can be expressed using the language of mathematics. The formal, technical language of mathematics is alone capable of realistically describing these natural laws. Language in its fundamental sense is language as a formalized sign language. The „natural laws“ are explications of an implicit logical order in nature. Language depicts this logical order through the logical structure of the linguistic sign system. The essential element of a language is therefore its syntax. Only through the syntax does the *logical structure of a language as a depiction of the logical structure of nature* come to light. Language as an image of lawfully structured reality is principally quantifiable because it is mathematicizable. Scientific research must concentrate on this aspect if it seeks to claim exactness.

The semantic aspect of language initially comprises an incidentally developed or combined symbol sequence which only gained significance in the course of specific selection processes. Here, substance in meaning corresponds to natural substance because the selection processes have evaluative function.

We merely need to study and explain all the possible criteria in the genesis of natural substance in order to *unmistakably* understand the substance of meaning. In Eigen’s language communication

model, language as a communication medium between communicative subjects remains an event of private and monologic character: language as an arbitrary sequence of linguistic signs whose meaning is derived from selection processes does not convey substance but merely structure. These structures can be expressed in binary codes (yes/no decisions). The linguistic signs are variables whose syntax is subject to laws governing the linguistic sign-using organ or the macromolecules. The brain of humans, for example, is endowed with these variables and combines them to reflect synapse network logic. The variable sign syntax of the brain must be filled with experiences of a personal nature and thus constitutes an individualized evaluation scheme.

In messages between communication partners, one side encodes the news he/she wishes to convey in phonetic characters; the receiver must then decode and interpret the message based on personal experience. Understanding messages shared between transmitter and receiver is principally possible since a uniform logical form - a universal syntax - lies hidden behind every language. Messages are therefore apriori intersubjective in form and structure, while the interpretation of content remains a purely private matter. The formal structure of species-specific languages is intersubjectively identical; therefore, only scientific formal languages, such as those used in mathematics and physics, can be properly designated as languages capable of accurately representing conditions of reality.

2.2. Language as an algorithmic decision-making process

The function of that organ which syntactically combines the language symbols according to its own structure most closely corresponds, in Eigen' opinion, to cybernetics, i.e., the theory of information-processing systems (while abstracting the manner of its realization). The functional units „central nervous system“, „brain“, and even „macromolecule“ consist of a definable, limited number of elements and a limited number of interrelationships between these elements; these make up the structure, the so-called systems structure, of these units.

Since we are dealing with living systems, active systems are present as well, i.e., there are elements in systems which mutually exert or endure active influence. The relational structures can be of a chemical-particulate and energetic nature or purely informational. Some of these systems will regulate themselves and react to particular environmental influences with greater or lesser success. Those reacting more successfully optimize their probability of reproduction. In the course of evolution, precisely those biological species which have best adapted to altered environmental conditions have prevailed. Certain types of systems create irreversible processes through self-organizational behaviour, leading to the preservation rather than the degeneration of successful structures; these structures continue to attract other evolutionarily successful structures, which enhances the complexity of the system and in turn optimizes its adaptability.

These systems, along with their description by means of language, are depictions of a reality structured by natural laws. Since both the logic of the describing and that of the theory-forming language corresponds with the logic of the system, the relationship between the elements of the system can be represented in an abstract, formal, and unambiguous manner. It is important to determine the relationship among the language signs, as their relationship reflects the relationship of order in the realm of nature.

The quality of the syntax is evident in the concept of information. Since messages based on

reality can be formally represented, they can be coded with 2 characters (0 and 1). This unit of measure enables the information content of a particular message to be determined with regard to the available number of available characters. This furnishes a calculatable, average information content of a letter of an alphabet below which one cannot drop without rendering letter identification impossible.

A receiver decodes and privately interprets the received information (albeit according to intersubjectively identical rules of an underlying logic common to all languages). Information theory therefore also involves information processing, i.e., various transformations of particular messages into other sentence structures according to specific transformation rules as determined by a machine.

Dynamic, self-regulating and information-processing cybernetic systems are considered to be the realization of algorithms. An algorithm defines that method by which, in a *finite* number of steps, a problem can be solved. Machines can calculate those functions for which an algorithm exists. Since reality is structured by a logical order subject to natural laws, the logical form of language (mirroring the logical form of reality) must be expressible in binary codes. Every message, every information, is calculatable and every problem is solvable algorithmically. Principally, an optimally constructed machine would be equipped with a more optimal syntax than humans.

2.3. Humankind as a learning machine

From the viewpoint of man as a machine, humans clearly represent an optimal model: they fulfil all those preconditions for the algorithm development that a conventional machine cannot deliver, i.e., criteria for information evaluation based on the real, social environment. Humans, and all other biological systems, resemble a learning machine capable of internally producing a syntactically correct image of the environment by interacting with this environment, of correcting this image through repeated interactions, and thus of changing the behavior toward the environment. Such learning systems are able to continuously optimize their adaptability. The learning efficiency is mirrored in a history of advantageous selections. This type of selection history is the history of the optimal realization of algorithms.

Processes of human consciousness can be best represented cybernetically because the brain - as the „learning machine“ in this model - understands itself best.

Reflection on reflection is a self-reproducing, dynamic, self-regulating behavior, a (transcendental) reflection of the machine; language, the common logical form of reality and reflection medium, is the precondition for its existence.

Ultimately, processes of consciousness are learning machine functions based on the input-output principle. Decoding the rules governing brain organization makes the decoding of all conceivable conscious processes possible. This approach transforms consciousness into an observable, accurately and unambiguously describable and quantifiable problem-solving behavior. The brain is structured in such a manner that it can transform the syntax inherent on its molecular level up into the phonetic level: The constitution of a formal language by the brain enables this „learning machine“ to recognize itself as a constitution of reality and to reflect on itself.

Here, Popper's theoretical viewpoint becomes relevant for Eigen. Accordingly, scientific research must be viewed as being analogous to the adaptive behavior of organisms to their environment: one can therefore refer to the (biological) evolutionary character of knowledge gain. The self-reproduction of the learning automaton is reflected in all levels of biological reality. Popper's 3-World concept enables Eigen to explain language in every sense, from the nucleic acid language to that of human reason.

The differences between these two languages stem from the continuous development process of biological structures, based on the model of a self-reproducing and self-regulating automaton *that functioned as a realization of algorithms*. This enabled the steady optimization of problem-solving strategies in organisms, eventually leading to the constitution of a central nervous system, a precursor ultimately giving rise to the brain and its enormous storage and information-processing capacity. Language enabled implementation of this evolutionary plan (from the amoeba to Einstein): this medium forms, transforms, stores, expands, and combines information.

This explains why Eigen sees language as the prerequisite for the development of all forms of life, as well as for the evolution of the mind. A uniform fundamental structure, the logic of the universal language, lies behind all living phenomena as well as behind the construction of the formal language which exactly reproduces this logic of reality (comprising both being and the discourse-on-being). Thus, the structure of information-forming and -processing systems such as the brain, the central nervous system, or the immune system mirrors „in its uniform basic structure, the theoretical approaches applied in its description“ (331).

3. Deficits in the picture theory of language

Even formal systems are not closed, as Eigen purports, nor are they principally fully determinable. Furthermore, language is the result of communicative interactions in dialogue situations rather than the result of constitutive achievements of the individual persons. Communicating with one another, sending messages, understanding expressions is not a private coding and decoding process, but rather an interpretation process arising from a mutual adherence to rules by communicating partners who agree on the rules.

The ability to abide by these rules is innate, the skill in complying with particular rules is acquired through interactions and relies on norms of interaction to utilize words in sentences. Information cannot principally be quantified as message content: statements made by social individuals in situational contexts are not closed and thus are *principally* not fully formalizable. The attempt to construct a purely representational language is *doomed to failure* because formal artificial languages do *not exclusively* contain terms that are unambiguous. This pertains to terms that cannot be confirmed through observation. **Specifically, scientific statements are not attributable to immediate sensory experience, i.e., the language game used to describe observations does not mirror the brain activity during the perception of reality.**

A world-depicting standard language must remain a mere postulate because it cannot logically substantiate itself. Too many theoretical concepts, too many scientific criteria that are principally not formalizable (e.g., „progress in the cognition process“, „practicability“, etc.), point to the limits of formalizability. The very identity between artificial language and its form renders it

incapable of reporting on itself, something that presents no problem when using informal speech. Language is an intersubjective phenomenon in which several individuals can share, alter, reproduce as well as renew the rules of language usage. The basis and aims of this usage are defined by the real social environment of interacting life forms. The user of a linguistic sign cannot be comprehended according to the speaker-outside world model. Rather, this requires reflection on the interactive circumstances to which the user has always been bound, circumstances which provide an underlying awareness enabling him/her to understand statements made by members of the real environment. The user of formal artificial languages - before appreciating the purpose of the usage - has also developed this prior awareness in the course of interactive processes with members of the real social environment.

Speech is a form of action, and I can understand this activity if I understand the rules governing the activity. This means I can also understand an act that runs counter to the rules. Everyday language usage reflects everyday social interactions of the constituent individuals. The prerequisite for fully understanding statements is the integration of the understander in customs of social interaction and not merely a knowledge of formal syntactic-semantic rules. *A prior condition* for all formalizations in scientific artificial languages is a factual, historically evolved, communicative experience. This very precondition becomes an object of empirically testable hypothesis formation in Eigen's language model. At this point, however, Eigen's model becomes *paradoxical* because he seeks to theoretically grasp language with tools that are themselves linguistically predetermined.

Even Chomsky's attempt to reconstruct universal systems of rules within an empirical theory of language (rules that have developed over the course of evolution, are genetically transmitted, and then „awakened“ through social interaction) is founded on a „generative grammar“ which itself is based on the mathematical analysis of formal systems (CHOMSKY. 1964 a, 1964 b). He attributes the rules governing sentence construction to the level of syntax, semantics, and phonology. To him, these rules are rules of a formal system. Chomsky himself, however, concludes that formal systems are principally incapable of doing justice to the complexity of sentence structure: sentences do not appear to be produced linearly, which should be the case in formal systems. According to this model, the generating system of rules must exclude real communicative acts and interactions and, with it, precisely the apriori of practical language usage.

Eigen's language model, which is rooted in information theory, clearly reveals that Eigen equates the form of theory language with the form of language used to describe reality (experience). This implies the equation of formalized scientific languages with the language used to describe observations. Previous attempts to specify all the rules governing the translation of every term in theory-language into terms of observational languages have been unsuccessful. Not all concepts of theory language can be transposed into concepts of the observational language.

A similar situation is encountered in the attempt to absolutize mathematics as that pure formal language whose every ramification might become fully transparent. This led Gödel to formulate the „Unvollständigkeitssatz“ („incompleteness theorem“) in his work „Über formal unentscheidbare Sätze der principia mathematica und verwandter Systeme“ (GÖDEL. 1931). Gödel investigated a formal system by applying arithmetic and related deduction methodologies. His aim was to convert the metatheoretical statements into arithmetic statements by means of a

specific allocation procedure. More precisely, he strived to convert the statements formulated in a metalanguage into the object language S by using the object language S. This led Gödel to two conclusions:

- a) Under the assumption that system S is consistent, then it will contain one formally undecidable theorem, i.e., one theorem is inevitably present that can be neither proved nor disproved. prov
- b) Under the assumption that system S is consistent, then this consistency of S cannot be proved. prov

The question of determinability and calculability is closely allied with the algorithm concept, whereby Eigen seems to postulate that algorithms are not only concepts of theoretical language, but also depict (decision-) behavior in the realm of biology and therefore are amenable to empirical analysis. Indeed, he is convinced that everything can be represented in the form of algorithms and can thus, in principle (after sufficiently thorough analysis), be determined. Yet Eigen never puts this to the test, i.e., he never states the conditions under which a branch of mathematics would be undecidable. Namely, a field of formalized artificial language is undecidable when no algorithm can be provided to help decide - for a particular formula of a formalized artificial language and involving a finite number of steps - whether this formula is universally valid or not.

Today, several branches of mathematics are considered undecidable. Herein lies the consequence of this undecidability theorem for the automaton theory of A. Turing and J. v. Neumann: a machine can principally calculate only those functions for which an algorithm can be provided. *Functions lacking an algorithm are not calculable.*

Every cybernetic, self-controlling machine is the realization of a formal system. Eigen assumes that the evolution of self-reproducing and self-organizing organisms represents the realization of the syntax of a universal language underlying the order of the world. This universal syntax, as a representation of mathematically expressible reality, is also the formal basis for the evolution of these organisms. For every one of these machines, as in the case of every organism, there must be an undecidable formula.

It is precisely by means of a *non-formal* language that this formula can be shown to be true or false; this non-formal language is the very tool that enables the language itself to be discussed. The machine is unable to do this because no algorithm is available with which a cybernetic machine can determine its underlying formal system. Systems theory is *principally* unable to fulfil the demands that Eigen places on it.

The fact that the paradoxes arising within an object language cannot be solved with that language led to a differentiation between object language and metalanguage. Nonetheless, paradoxes can also appear within metalanguage; these can only be solved by splitting into metalanguage, meta-meta language and so forth in an infinite number of steps. This unavoidable gradation of metalanguages necessitated resorting to *informal speech, developed in the context of social experience, as the ultimate metalanguage. It provides the last instance for deciding on the paradoxes emerging from object- and metalanguages.* Neither the syntax nor the semantics of a system can be constituted within that particular system without resorting to the ultimate metalanguage.

The ambition to provide logic and mathematics with apriori validity is *no longer tenable*: an unambiguous linguistic fundament of science, one beyond further inquiry and supporting itself through direct evidence, cannot be secured. Language proves to be a perpetually open system with regard to its logical structures and cannot guarantee definiteness from within itself. This is the very conclusion that Eigen disputes with his language model. To briefly summarize this chapter:

(a) There can be no formal system which is entirely reflectable in all its aspects while at the same time being its own metasystem.

(b) Concrete acts and interactions are principally unlimited in their possibilities. There will always be lines of argumentation that lie outside of and have no connection with an existing system. Principally, every system can be transcended argumentatively. Newly emerging language games and rules may develop as novel structures which are foreign to previous systems and not merely a further step in a series in prevailing elements. These very discontinuities enable totally new language applications.

(c) The ultimate metalanguage, informal language, provides indispensable evidence about the communication practice of subjects in the real environment; the operator of formalizations is himself an integral part of this. Reverting to this everyday type of communication reveals information about the subjects practising this usage. In this sense, pragmatism becomes the theoretical basis both for formal operating and for a non-reductionistic language theory.

Thus, Manfred Eigen (representing molecular biology and biochemistry) fails in his attempt to use the language and communication concept to explain observed biological phenomena and processes. Eigen is correct in recognizing that language and communication were and continue to be indispensable for the origin of life, the development of biological species diversity, as well as for the specifically human capacity for thought, speech, and action; at the same time, he is unable to provide an adequate foundation of these two terms. This casts doubt on the entire explanatory model for living nature as provided by the biological disciplines.

The inevitable question is: how can the use of the terms language and communication be expanded so that both concepts provide not only a sufficient explanation, but also an *understanding* of living nature?

4. Language pragmatism as a basis for a semiotically expanded language and communication concept in behavioral, socio-, and molecular biology

The insurmountable explanatory deficits in the picture theory of language, as determined above in Manfred Eigen's usage of the terms „language“ and „communication“, require an expansion of the explanatory horizon he forwarded. The inability of cybernetic systems theory or information theory to establish and justify the application of either concept to explain central processes and structures of living nature is apparent; *further usage in the sense of Manfred Eigen would make this approach liable to criticism as an anthropomorphism* or would reduce it to mere metaphorical character. In my opinion, the expanded explanatory horizon for the application of „language“ and „communication“ to explain and understand living nature could take on the following form:

4.1. Language as a medium of understanding. The apriori of the pragmatic situation of understanding

Organisms that communicate with each other by means of linguistic signs can correspond by coordinating their behavior. They represent real forms of life in a real, animate world. Language is necessary as an intercommunication medium for the overall organism, not only externally to develop optimal action criteria, but also internally to explore optimal reaction criteria.

The disruption of either external or internal communication can seriously endanger the survival of the organism as a whole, even if the pathways are completely different. The ability of organisms to adapt to changing environmental conditions is not the only result of successful internal and external communication. *The creativity, nonlinearity, and productive scope of new genetic texts, which serve as the construction and development plans for organisms, indicate the avenues that language and communication open up.* Indeed, their realization is difficult to explain without the assumption of sign-mediated communication processes.

Both, self-organization in autocatalytic processes and the creativity of human intellect require language and communication as the realization medium. From this perspective, language and communication serve as a *precondition for the possibility* of life (versus non-living matter), the evolution of biological species, and for the cultural evolution of human reason; Manfred Eigen is entirely correct in this respect.

Since users of linguistic signs can combine a finite number of characters with a finite number of rules to carry out an *infinite number* of sign-mediated communication processes, language and communication become the structural and organizational medium for biological species. Sign-mediated communication processes allow leaps in the evolution of biological species to be understood because such leaps are ultimately creations of genetic text combinations; these have not developed from random, undirected changes in the genetic text, but rather were *initiated by protein individuals (enzymes) which are highly competent in the combination and recombination of genetic text sequences.* They are so highly competent that gene manipulators rely almost exclusively on this competence.

Reflection on the pragmatic intercommunication situation also helps us understand the *leaps in scientific knowledge*, whose critical phases are discontinuous and nonlinear (KUHN. 1970). While Manfred Eigen points out the similarities in such discontinuous and nonlinear processes, he is unable to explain this similarity on the basis of his language model.

Language enables constative and regulative language activity (or language behavior in nonhuman biological individuals) much more so than mere generative language activity (or -behavior). They help organize the everyday social environment in which organisms are immersed throughout their individual lifespans. Nonetheless, *linguistic-sign-utilizing individuals are equally capable of conducting generative language activities or -behavior*; here, new activities or new behavior, new rules, are constituted which themselves normatively orient further activities or behavior sequences.

Linguistic-sign-using individuals are principally able to create entirely new activities, new

behavior, completely new texts, completely new genetic texts in different realms (macro-level: domain involving phenomena of sensory perception; micro-level: domain of molecular interactions). These creations do not logically evolve from existing networks according to pre-existing rules; rather, they constitute something **new**, something foreign to that already in existence. This is precisely what Eigen's language model *cannot* explain, because Eigen neglects the constitutive capability of the pragmatic situation. *He thus eliminates the preconditions for his own theory development.*

4.2. No generative grammar without generative pragmatism

Generative grammar states that every sentence of a language (initially the underlying structure and then, with the help of transformation rules, the overlying structure) can be created. Accordingly, a linguistic-psychological theory of human language would be an empirical science whose object of study would be the preconditions for its existence. This would further raise the prospect for providing a linguistic foundation of logic - the question involving the difference between analytic and synthetic judgements would then lend itself to a linguistic solution. However, logic can hardly be founded by an explanatory, empirically testable theory (which itself presupposes logic).

The attempt to understand the subconscious adherence to grammatical rules when expressing and interpreting remarks as an extension of naturally governed behavior is *doomed to failure*: how linguistically competent individuals adhere to rules of grammar cannot be equated with how water crystallizes into ice or melts again to liquid form. Following rules of grammar in speech (or writing) can itself become the topic of speech and can be intentionally altered, distorted, or even violated. This very creativity to change rules forms the much valued artistic quality of linguistic endeavor and enables poetic and speculative language usage along with novel types of rationality, thought patterns and lifestyles. *The difference between rules of grammar and natural laws is unbridgeable.* Humankind cannot determine the degree of its adherence versus nonadherence to natural laws; we can, however, define this relationship with regard to grammatical rules at will. Even the rule-altering creativity in the realm of DNA indicates that **natural laws cannot explain** rule changes, i.e., innovation at the level of genetic text sequences. This pertains to those changes stemming from the activity of protein individuals competent in text modification, not to deformations of genetic text sequences arising randomly from external influences (for example radioactive radiation, chemically induced mutations, etc.).

Sign-mediated communication is a regulated interactive event between interactive individuals. The rules of sign usage are therefore a component of social norms, of normative activity or behavior, for which the interactive event is constitutive. This interactive event should not be reduced in a behaviouristic manner, since the interpreter himself/herself is a member of the social community that intersubjectively made interpretation experiencable. Interaction events are principally grasped subjectively before they can become the topic of objective description or explanation.

In humans particularly, the discussion about norm consciousness is not reducible to internalized or innate rule adherence. The constitution of this norm consciousness is the consequence of a social interactive event in a real environment. Equally, Eigen's postulate of an evaluation function that selects the universal grammar from all possible alternatives, shifts transformation

grammar in the direction of a theory of (finitely deciding) automata and thereby relates to a possible algebra of linguistic computer programs. The aim of such a theory may well be the successful computer simulation of human language behavior, as was planned by A. Turing and J. v. Neumann and which an entire generation of researchers from numerous scientific disciplines has since set their *hopes* on. In this case one must systematically avoid *confusing* the simulation of human speech with speech itself. Even if machines could simulate how humans abide by rules, they themselves do not actually follow such rules, but „merely function in accordance with certain formal procedures“ (SEARLE. 1984). The machine simulates certain formal characteristics of mental processes.

By loosely employing the term information (or: information processing) for such entirely divergent phenomena as the adherence of humans to rules on the one hand and the simulation of human rule adherence on the other, Eigen glosses over the confusion between human rule adherence and „as if“ human rule adherence by machines.

The purely mechanical „as-if“ simulation could be transcended if a successful communication took place between computer and human subject, for example **in the form of a non-formalizable self-reflection**. This would, however, principally exclude Gödel's indeterminability theorem.

4.3. From (privatistically conceived) generative grammar to apriori pragmatic speech situations

The Eigen language model interprets language as a monologic conveyance of information. According to Eigen, the fact that the speaker has a command of linguistic sign utilization (rules of language usage) is not due to co-constitution through a learning process involving social interaction in which socially integrated individuals master the meaning of linguistic signs in real-life communication situations. Rather, this is determined exclusively by its apriori identity with the logic behind the „system“ central nervous system or brain. Thus, the social interaction process would merely stimulate this innate capability; in reality this shared rule-understanding is an instinct-analogous process.

The theoretical perception of the information exchange process purely as message transmission *neglects* the constitutive contribution of those involved in the interaction process; communication is reduced to the genetically acquired language competence of the respective communication partner. Accordingly, each of these participants carries all the linguistic prerequisites apriori within him/herself, specifically within the language-forming organ. Both speaker and listener are viewed as entirely separate individuals. Although both are equipped with the same program, i.e., they abide by the same natural laws and can therefore establish a quasi-intersubjectivity about the validity of identical meanings, they remain entirely privatistic in their conception. Thus, the precondition for the constitution of meaning is not the apriori involving the understanding among individuals that share and communicate in a common environment.

Rather, the ultimate factor lies in the phonetic process between C and C' (Fig. 1), where information is conveyed between a speaker and a listener who use their individually given language competence and the apriori identical language to put their individual thoughts into words and to code them or, vice-versa, to decode and understand the contained information.

When members in the real environment communicate with each other about something (e.g., the coordination of behavior), Eigen argues that the meaning of this „something“ is ultimately constituted through syntactic rules. My aim here is to demonstrate how and why the meaning of this „something“ *is constituted in pragmatic speech situations*.

In a theory of language based on pragmatism, the sentences and texts of idealized speakers in syntactic/semantic theories are replaced by the remarks of speakers in idealized speech situations. The theory of speech competence must be supplemented by a pragmatism of the speech situations (theory of communicative competence); this can clarify the preconditions under which language is used to achieve understanding about something, i.e., under which conditions the contexts of activity or behavior constitute meanings of linguistic expressions.

Only the pragmatic, inherent structure of such communication situations can reveal, under scrutiny, *why a speaker shows what he/she means with what he/she says* (VOSSENKUHL. 1982). These meanings are in no way formalizable, and every operator of a formalization has presupposed and applied these pragmatic conditions long *before* actually knowing what formalization is. The underlying pragmatic structure provides a means of principally understanding even grammatically irregular sentences in speech situations; a purely grammatical analysis of such an anomaly may very well be confronted with insolvable paradoxes. The pragmatic level also provides hermeneutic access to an understanding of the rule-changing creativity process, which enables the sign user to design and express entirely new sentences, to conduct new activity, to develop new behavior - all in no way logically derivable from pre-existing states. Grammatical competence can never be fully separated from the communicative competence constituted in speech situations: assuming one without the other cannot adequately explain a sign-mediated communication (APEL (Ed.). 1976 a; HABERMAS. 1985; SEARLE. 1976;).

Eigen's reliance on Chomsky's generative grammar in no way eliminates the deficits of his language model.

4.4. The constitution of meaning and understanding through real intercommunication processes

Analysis of Eigen's language model shows that his language and communication concept **is insufficient** to comprehend and reconstruct human language usage and requires amendment through pragmatic points of view. Indeed, these pragmatic viewpoints of language usage largely determine our understanding of the adherence/non-adherence to grammatical and semantic rules. This is particularly evident in the attempt to analyse unconventional language usage (WUNDERLICH/MAAS. 1972; WUNDERLICH. 1976).

The pragmatic intercommunication situation is characterized by a complementarity that is indispensable for the constitution of meaning or, in Eigen's words, for the evaluation scheme and the allocation of meaning to symbol combinations. Sign-mediated communication can only extract meaning from signs within a setting involving a reciprocal confirmation between language usage and daily life; for the sign-using subject, this transparent framework enables meaningful expression and permits successful intercommunication about a chosen topic. The pragmatic sign-usage situation is *ultimately constitutive* for the meaning of language application

and speech behavior. Wittgenstein termed this situation „language game“ and K.O. Apel very aptly differentiated this term as „a ‘life-form’, a functioning unit of language usage, living expression, behavioral custom, and worldly openness (APEL. 1976 a, p. 321).

Meaning can only be grasped in the framework of (real or fictitious) participation in such language game. Language game even exists, or so we as humans can assume, in those cases where conspecific individuals exhibit species-specific behavior that takes on sign character whose particular meaning can be understood by the language game participants of that species. This remains valid even when we consider the differences between human and non-human, sign-mediated communication. An example is that specifically human quality in which the rules governing the sign-mediated communication are concurrently maintained as rules in the reflective consciousness and can often even be formulated as explicit rules.

The meaning constitutes itself through the specificity of the actual intercommunicative situation (whose purpose may be sociality or the coordination of activity or behavior); no one can seriously dispute such behavioral coordination in non-human biological individuals. *The pragmatic approach also explains how the same linguistic signs can take on different meaning in the various language games. Shifts in linguistic sign meaning are an integral and important component in specific language game situations.*

In the process of communicative interactions, norms - which serve to orient our activity and govern behavior - can be nullified or modified. The pragmatic language usage of individuals involved in species-specific, sign-mediated communication processes (language game, etc.) enables the change, expansion, and transformation of proven and conventional sign meanings. This gives rise to the possibility, even the *probability*, of an evolutive self-organization of organisms, one that involves a discontinuous differentiation of ever more complexly structured organisms, initially via intra-organismic communication processes.

This self-organization cannot in fact be explained or even understood (as Eigen postulates) as an algorithmic process; rather, it is a regulated, sign-mediated (and consequently linguistic) communication process between a) the protein individuals of a biological organism, b) conspecific individuals, c) conspecifics and external environment.

Evolutive self-organization is an evolutive possibility when intra-, inter-, and meta-organismic communication function in an equally complementary fashion and when they can claim language-mediated, rule-changing creativity.

An explanation of how to constitute irreversible processes - in particular with respect to a competent expansion or advantageous alteration of the genetic text through enzyme proteins - would hardly be possible: without assuming this complementarity, how could one understand the acquisition of a social interaction competence, much less the genetic fixation of specific, crucial experiences (WILSON. 1985)?

Sign-mediated communication in non-human languages is also clearly oriented toward pragmatic conditions; it constitutes meaning and significance here as well. Examples include the bee language as well as inter- and intracellular communication (FRISCH. 1971, WITZANY. 1993 b).

4.5. No intra- and intercellular, sign-mediated communication processes without real sign-users

The genetic code which is fixed in DNA and read, copied, and translated in gene expression gains importance as a genetic text only if real sign-users are available to read, copy and translate it into the amino acid language. This gene expression, along with all of the related subprocesses is neither mechanistic nor mysterious and vitalistic. Rather, it is the result of complex, regulated interactions and highly specific behavior coordination between numerous types of enzyme proteins (WATSON. 1983).

These enzymes clear the text for reading, implement the copying into the three types of RNA, search the text for superfluous text passages, cut these out, to a certain extent repair damaged sections using rougher and finer techniques (excision- and postreplication repair), and complete the entire process of normal gene expression (HOWARD-FLANDERS. 1981). All enzymatic protein individuals are themselves coded as genetic sequences, yet enzyme proteins themselves always clear genes for reading and thus ensure the reproduction of all necessary enzyme proteins. This allows numerous generations of specific enzyme protein types to exist within the life-span of an organism, beginning at the onset of life.

The technique employed in the reproduction of the enzyme types is the same in all organisms in which genetic texts must be read, copied, and translated into the amino acid language. Every cell of the entire organism stores the complete genetic construction plan in the form of the genome, although only those text passages required for the function of the particular cell association are expressed. This also means that the specificity of the cell association is *decisive for evaluating* those passages (within the total genetic text) that are to be read, copied, and translated. Every organ, i.e., every specific cell association in which specifically associated cells must carry out a function for the complete organism (in a complex coordination with other organs), requires regulated interactions in order to fulfil the demands placed on it by the organism (e.g., raised pulse rate after physical exercise).

Today we appreciate how complex the execution of this sign-mediated communication is in specific communication situations and within specific requirement profiles (WITZANY. 1993 a). The communication between cells of a cell association (organ) is irrevocably limited to this context, i.e., the irreversibility is genetically fixed and virtually guarantees abundance by the rules that govern the reproduction of cell-association-specific progeny: we can be certain that liver cells reproduce only new liver cells.

At the same time, the specific position within a cell association determines the expression of those genes which code for the (punctual) reproduction of a cell in *precisely this specific* position. *The actual position of a cell in the real environment is the evaluation criterium for the gene-expressing enzyme* to express exactly that segment of the total genetic text which enables the reproduction of a cell in that and no other position (GEHRING. 1986).

Highly specific cell communication between cells of a cell association further enables the production of proteins required for the various functions (e.g., metabolism function) within the complete organism. The required proteins are not infrequently produced by very different cell associations via very cell-association-specific communication processes (WITZANY. 1993 b). The rules of these sign-mediated communication processes, both of the intra- and intercellular

type, are followed, occasionally even newly constituted, by real users of linguistic signs. They (the rules) are not only structured by the syntax of the genetic text, but also by the real environment of the complete organism; this itself constitutes situational contexts and contexts of experience, or finds itself within such contexts, and is primarily responsible for imposing special tasks/demands on cell associations.

Specific task-accomplishing strategies can be (but need not be) genetically fixed as experiences. This indicates that text-generating enzyme proteins use specific stimulatory patterns of the organism, which are the result of situational contexts in a real environment, as a basis for their text generating activity. Such stimulatory patterns may be neuronal or may function in combination with chemical messenger substances as text-generating stimulatory patterns. Interestingly, evidence for this was provided not by socio- or molecular biologists, but by biochemists (BONNER. 1983; WYLES/KUNKEL/WILSON. 1983; WILSON. 1985).

Protein synthesis probably takes place in all organisms in the same manner. Otherwise one would not be able to arbitrarily combine the mRNA, tRNA and ribosomes of completely different species of organisms in a cell-free environment. The nucleic acid language is governed by a common syntactic law, yet the real environment of protein individuals, of the cell components and cell associations, as well as of those organisms whose life is maintained by these cell associations, determine the use of this language; they initiate the generative, sign-mediated communication processes (i.e., not random mutations due to radiation or mutagenic agents) in which this language is changed, transcended in its meaning, newly combined, or its complexity increased or reduced. *Real environments and the interacting, rule-abiding individuals that constitute them are co-constitutive for the sentence structure of the genetic texts* (WITZANY. 1993 b, 1994).

*Without a **molecular pragmatism**, neither the logic of the molecular syntax nor the molecular semantics that Eigen deduces from it could be understood; furthermore, their explanation would remain reductionistic.* Understanding the language of nature (nucleic acid language) requires a **molecular semiotics** (WITZANY. 1993 a) that analyses and interprets the molecular interaction processes as sign processes (semioses). This would reverse the omission of the actual sign users in the intra- and intercellular communication processes and would incorporate their co-constitutive role in the structure of the genetic text and its expression.

This level of insight must be attained before one can legitimately refer to a language of nature: then we are no longer dealing with an explanatory model operating with metaphorical terms, but have an approach that enables us to understand and substantiate the conditions that establish the possibility of living organisms.

As long as molecular biology considers language to be an apriori for the evolution of organisms and, ultimately, also of human intellect, it has grasped language only syntactically/ semantically.

From the standpoint of language philosophy, we can legitimately refer to a language of nature in the evolution of organisms and in the evolution of human reason only after incorporating the pragmatic dimension of sign utilization and thus including both the real environment of the sign user and an understanding of its life-form.

A further example of how linguistic signs are constituted with meaning *through the pragmatic usage context* is provided by chemical messenger substances whose structure is the same but whose meaning differs in different communication processes. Thus, the same chemical messenger can assume an entirely different messenger function as a hormone than as a neurotransmitter in the communication between nerve cells.

The constitution of immunological memory is yet another example of how the interaction competence of the B-lymphocytes is co-constituted through pragmatic interaction:

After successfully warding off an infection, the B-lymphocytes which helped organize the defense remain present in the body as an immune memory. In the event of a renewed infection the immune response can proceed much more rapidly and more effectively. The immune response itself, however, is not genetically fixed, merely the structure of those proteins that organize the immune response. The immune response is the result of a complex identification and interaction process (TONEGAWA. 1985). On the other hand, the constitution of the immunoglobulins, in their incredible diversity, is the result of the variable combination of respective DNA sequences.

Here as well, sequence segments are not changed and combined automatically or randomly, but rather through *enzyme proteins with combinatory competence*. Using relatively few, variable sequence regions and following only a few rules, they produce a sheer endless number of *easily distinguishable* identification proteins, which help organize a successful immune response. Highly complex interaction forms and mutually complementary communication types (intra-, inter-, and meta-organismic communication), not random sequence mutations, have led to the development of such an immune response competence. If the organization and structuring of such relatively simple biological processes is controlled by *highly complex enzyme sign processes*, then how much more plausible is the assumption that such sign processes are involved in actual evolutionary processes, in which much more complex symbol processes are required?

Enzyme proteins in particular, which combine and recombine genetic texts, provide evidence for an evolutionarily acquired competence in text processing. More specifically, recombination enzymes identify particular recognition sequences as such and use this ability to carry out combinatory operations on the genetic text; in this manner they cut out semantically significant text sequences from the text assemblage and insert them somewhere else in the assemblage. The sequence combination itself is governed by syntactic rules; the exact nature of their combination is under the influence of pragmatic conditions. *The real environment of the affected cells and molecular structures of a complete organism form the evaluation function which constitutes the actual text combination as a meaning function.*

The metaphor involving the „language of nature“, as applied by molecular biologists, should not be rejected out of hand. Nevertheless, to justify referring to a language of nature in the language-philosophical sense *requires an expansion of the reductionistic language concept of molecular biology*. This would enable an understanding of living nature based not on metaphors but on a reconstruction of historical intercommunication situations and forms. The discussion about the language of nature opens new interpretation possibilities for observations in the realm of living nature - avenues that would principally be closed to reductionistic research methods.

References

- APEL, K.O. (1976 a) (Hg), Sprachpragmatik und Philosophie. Suhrkamp, Frankfurt
- APEL, K.O. (1976 b), Transformation der Philosophie. 2Bde, Suhrkamp, Frankfurt
- AUSTIN, J.L. (1962), How to do Things with Words, Oxford University Press, London
- BONNER, J.T. (1983), Kulturevolution bei Tieren. Parey, Berlin
- CHOMSKY, N. (1964 a), The Logical Basis of Linguistic Theory. In: Proceedings of the 9th International Congress of Linguistics (Cambridge, Mass. 1962), The Hague
- CHOMSKY, N. (1964 b), Current Issues in Linguistic Theory. The Hague.
- DARNELL, J.E.jr. (1985), RNA. Scientific American, vol. 253, No. 4, p. 54
- DAVIDSON, D, Harman, G. (1972, eds.), Semantics of Natural Language. Dordrecht
- DELBRÜCK, M. (1987), Der kartesische Schnitt. In: Küppers, P.O. (Hg) Leben = Physik + Chemie, Serie Piper, München, pp.237-251
- EIGEN, M. Winkler, R. (1975), Das Spiel - Naturgesetze steuern den Zufall. Serie Piper, München
- FRISCH, K.v. (1971), Bees: Their Vision, Chemical Senses and Language, revised ed. Cornell University Press, Ithaca
- GEHRING, W.J. (1984), Genetische Architektur: Ein Lebewesen nimmt Gestalt an. Bild der Wissenschaft, Stuttgart, Heft 11/84, p. 78-89
- GOODWIN, B.C. (1978), A cognitive view of biological process. In: Journal of Social and Biological Structures 1, pp 117-125
- GOODWIN, B.C. (1984), Changing from a evolutionary to a generative paradigm in biology. In: Evolutionary Theory: Path into the Future, Pollard, J.W. (ed.) John Wiley and Sons, London, pp 99-120
- GÖDEL, K. (1931), Über formal unentscheidbare Sätze der Principia Mathematica und verwandter Systeme. In: Monatshefte für Mathematik und Physik, 38, p. 173-198
- HABERMAS, J. (1985), Theory of Communicative Action, Vol. 1, Heinemann, London, Vol. 2 (1989), Blackwell
- HOFFMEYER, J., Emmeche, C. (1991), Code-duality and the semiotics of nature. In: On Semiotic Modeling, Myrdene Anderson, Floyd Merrell (eds.) Mouton de Gruyter, Berlin/New York, pp 117 - 166.
- HOWARD-FLANDERS, P. (1981), Inducible Repair of DNA. Scientific American, vol. 245, No. 5, p. 56
- KUHN, Th.S. (1970), The Structure of Scientific Revolutions. University of Chicago Press, Chicago
- LAKOFF, G. S., Ross, J.R. (1970), Is Deep Structure Necessary? (Ms.), Cambridge
- LAKOFF, G. S. (1987), Women, Fire and Dangerous Things: What Categories Reveal about the Mind. University of Chicago Press, Chicago
- PATTEE, H.H. (1981), Symbol-structure complementarity in biological evolution. In: The Evolutionary Vision, Jantsch, E. (ed.), Boulder, Westview Press, pp 117-128
- PRIGOGINE, I. (1980) From Being to Becoming. Freeman, San Francisco
- PRIGOGINE, I. Stengers, I. (1984), Order Out of Chaos. Man's new Dialogue with Nature. Heinemann, London
- SEARLE, J.R. (1976), Speech Acts. An Essay in the Philosophy of Language. Cambridge University Press, Cambridge
- SEARLE, J.R. (1984), Minds, Brains and Science. Harvard University Press, Cambridge
- SEBEOK, Th.A. (1979), The Sign & Its Masters. University of Texas Press, Austin
- SEBEOK, Th.A. (1989) The semiotic self. In: Semiotics, Self and Society, Lee, B./Urban, G. (eds.), Mouton de Gruyter, Berlin.

- TONEGAWA, S. (1985), The Molecules of the Immune System. Scientific American, vol. 253, No. 4, p. 104
- VOSSENKUHL, W. (1982), Anatomie des Sprachgebrauchs: Über die Regeln, Intentionen und Konventionen menschlicher Verständigung. Klett-Cotta, Stuttgart
- WATSON, J.D. et.al. (1983), Recombinant DNA. Scientific American Books, New York
- WILSON, A.C. (1985), The Molecular Basis of Evolution. Scientific American, vol. 253, No. 4, page 148
- WITZANY, G. (1993 a), Zeichenprozesse als Bedingungen der Möglichkeit von Leben und Evolution: Zur Notwendigkeit einer Molekularpragmatik. In: Zeitschrift für Semiotik, Bd 15, Heft 1-2, Stauffenburg, Tübingen, Seite 107-125
- WITZANY, G. (1993 b), Natur der Sprache - Sprache der Natur. Sprachpragmatische Philosophie der Biologie. Königshausen + Neumann, Würzburg
- WITZANY, G. (forthcoming), Semiosis and Evolution, In: Proceedings of the 5th International Congress of the International Association for Semiotic Studies, Berkeley, June 12 - 18, 1994
- WUNDERLICH, D. MAAS, U. (1972), Pragmatik und sprachliches Handeln. Suhrkamp, Frankfurt
- WUNDERLICH, D. (1976), Sprechakttheorie und Diskursanalyse. In: Apel, K.O. Sprachpragmatik und Philosophie, Suhrkamp, Frankfurt. Seite 463-488
- WYLES, J.S. KUNKEL, J.G. WILSON, A.C. (1983), Birds, Behavior, and Anatomical Evolution. In: Proceedings of the National Academy of Sciences of the United States of America, Bd. 80, Heft 14/84, S. 4394-4397